

DETAIL A  
SCALE 1 : 4

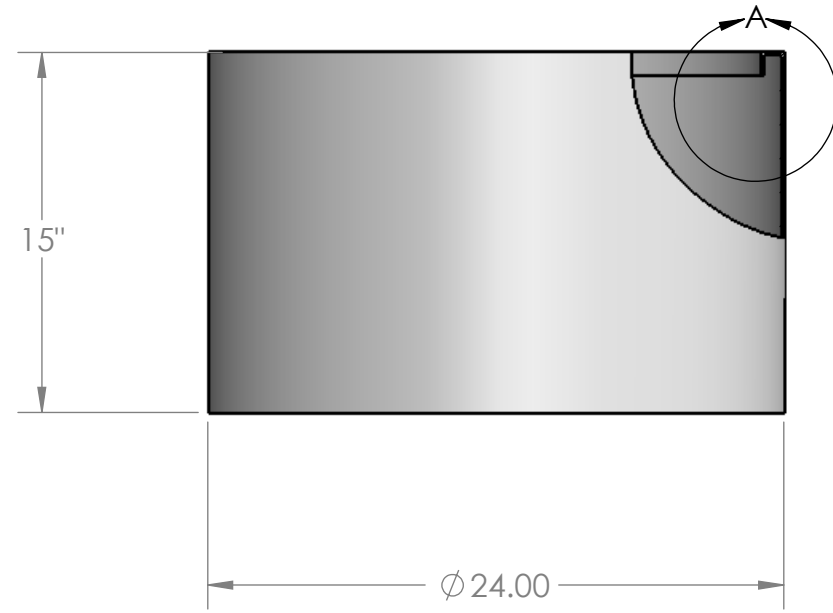

NOTES:

1. MATERIAL: HDPE
2. CAPACITY: 30 GALLONS
3. MOLDED WEIGHT: 11 LBS.

**PROPRIETARY AND CONFIDENTIAL**  
THE INFORMATION CONTAINED IN THIS DRAWING IS THE SOLE PROPERTY OF <INSERT COMPANY NAME HERE>. ANY REPRODUCTION IN PART OR AS A WHOLE WITHOUT THE WRITTEN PERMISSION OF <INSERT COMPANY NAME HERE> IS PROHIBITED.

		UNLESS OTHERWISE SPECIFIED:		NAME	DATE	CUSTOM ROTO-MOLDING, INC.			
		DIMENSIONS ARE IN INCHES		DRAWN	EBW	4-26-12	TITLE: <b>30 GALLON OPEN TOP TANK</b>		
		TOLERANCES:		CHECKED					
		FRACTIONAL ±		ENG APPR.					
		ANGULAR: MACH ± BEND ±		MFG APPR.					
		TWO PLACE DECIMAL ±		Q.A.			SIZE	DWG. NO.	REV
		THREE PLACE DECIMAL ±		COMMENTS:			<b>B</b>	<b>30 OTT</b>	
		INTERPRET GEOMETRIC TOLERANCING PER:				SCALE: 1:8		WEIGHT:	SHEET 1 OF 1
		MATERIAL							
		FINISH							
NEXT ASSY	USED ON	DO NOT SCALE DRAWING							
APPLICATION									